



Shown in Satin Brass

## 819 SERIES

### FL-819-V1.0 FLOOR LAMP

Slightly larger in scale than the TL-819, the floor version offers the same shielded source and low wattage LED downlight.

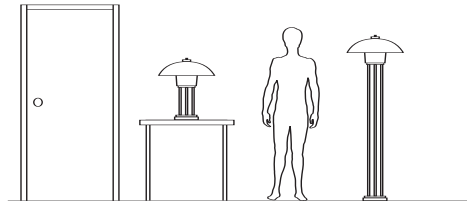
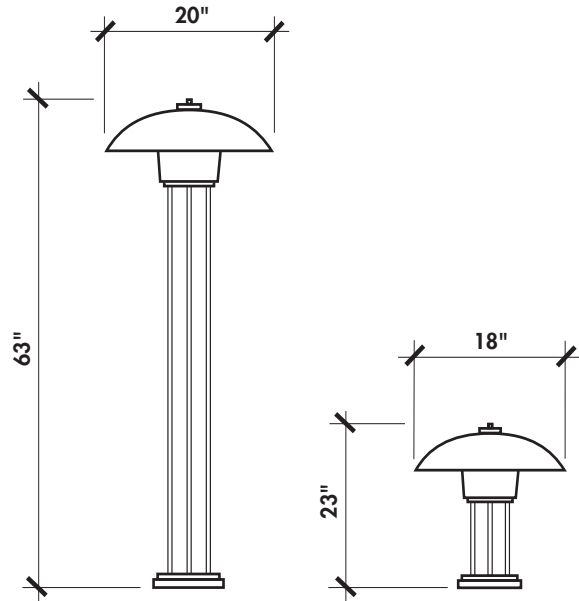

### TL 819 & FL 819 OPTIONS

- **LED DOWNLIGHT:** For low wattage (1.5 watts) night light, specify suffix **NL**, for higher wattage (6 watts) task light, specify suffix **TL**. Note that the night light is amber and the task light is warm white.
- **DOME:** Choice of luminous recycled polyethylene or opaque metal dome. Specify **LD** or **MD**.
- **FAUX ALABASTER:** Luminous dome available with a hand-applied faux finish.
- **DIMMING:** Advance electronic ballast with 100-15% dimming range.
- **CORD:** Two-conductor cord with polarized plug available in black or white. Specify **BLK** or **WHT**.

### VARIATIONS (Call factory)

- Mixed or special finishes
- Variation in overall height
- Fixed mounting
- Eliminate switch

## SPEC GUIDE



VERSION	CAT#	LAMP	FINISH	DOME	CORD	OPTIONS
<input type="checkbox"/> TL TABLE	<input type="checkbox"/> 819-V1.0	CF2/26	<input type="checkbox"/> SAL	<input type="checkbox"/> LD	<input type="checkbox"/> BLK	<input type="checkbox"/> NL
<input type="checkbox"/> FL FLOOR			<input type="checkbox"/> SB	<input type="checkbox"/> MD	<input type="checkbox"/> WHT	<input type="checkbox"/> TL
			<input type="checkbox"/> AB			<input type="checkbox"/> FAUX
						<input type="checkbox"/> DIM

SAMPLE SPEC: TL-819-CF2/26-SB-LD-WHT-FAUX

